

VENTWOOD[®]

PRE-ASSEMBLED WOOD PANELS

A quality modular system used for high-design ceilings, partitions, acoustical wall applications; as well as sun screens, decks, etc.

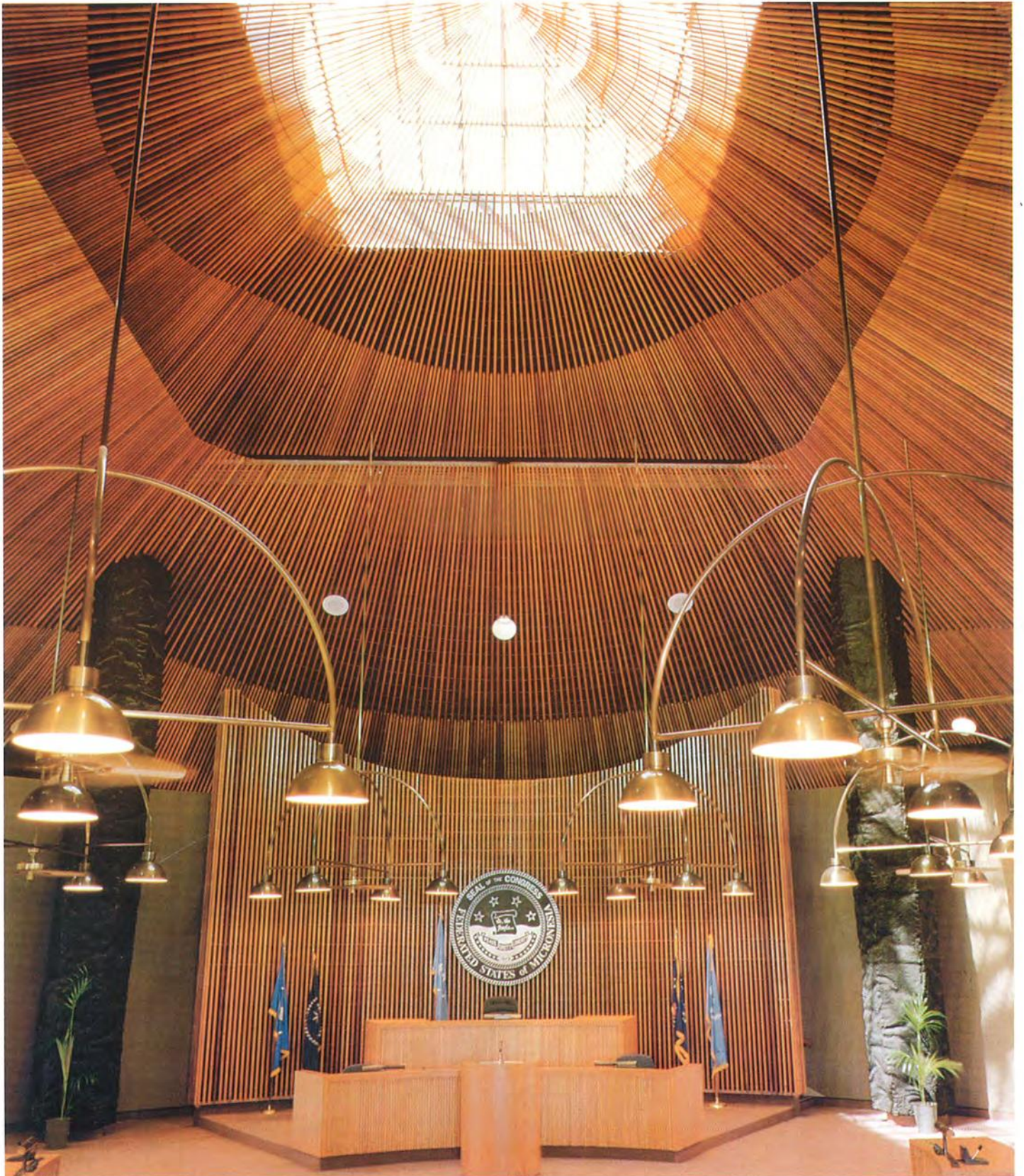

Capitol Complex, Federated States of Micronesia, Pohnpei / Architects Hawaii LTD - Photo by Robert E. Kulesh

1248



1 3/8" FRAMING THICKNESS

664



1 1/16" FRAMING THICKNESS

684



1 1/16" FRAMING THICKNESS

784 OJ



1 1/16" FRAMING THICKNESS

4124



3/4" FRAMING THICKNESS

5124



3/4" FRAMING THICKNESS

685



1" FRAMING THICKNESS

785



1" FRAMING THICKNESS

658



1 3/8" FRAMING THICKNESS

758



1 3/8" FRAMING THICKNESS

488



1 3/8" FRAMING THICKNESS

688



1 3/8" FRAMING THICKNESS

788



1 3/8" FRAMING THICKNESS

12 INCH MODULE

4128



1 3/8" FRAMING THICKNESS

6412J

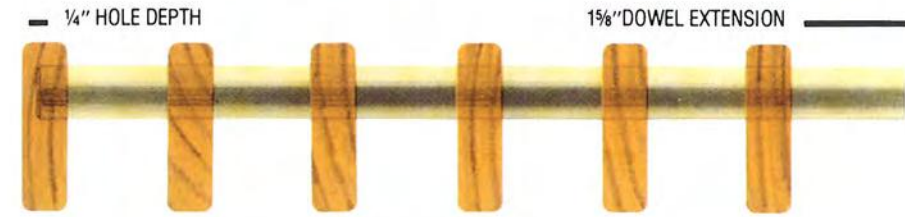

2 5/16" FRAMING THICKNESS

8412J



2 5/16" FRAMING THICKNESS

4812

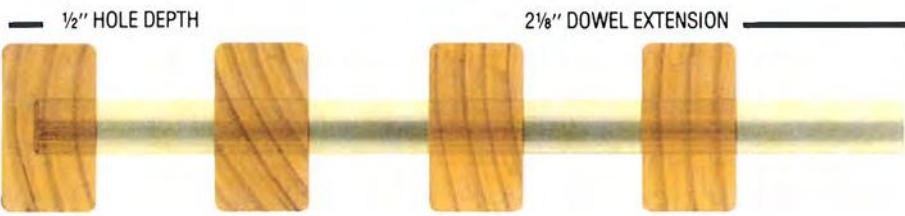

2 3/8" FRAMING THICKNESS

5812

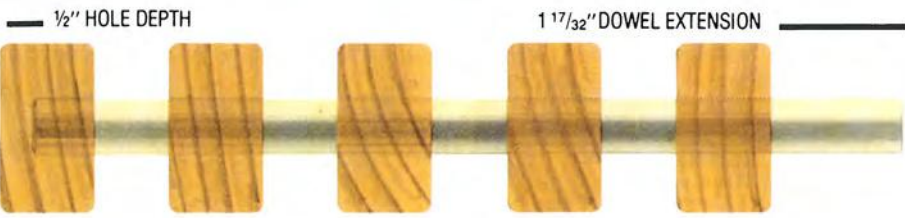

2 3/8" FRAMING THICKNESS

6812

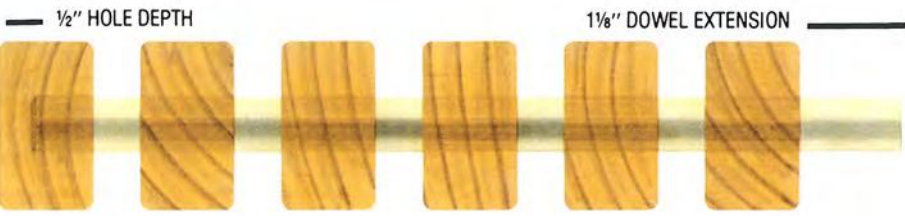

2 3/8" FRAMING THICKNESS

678R

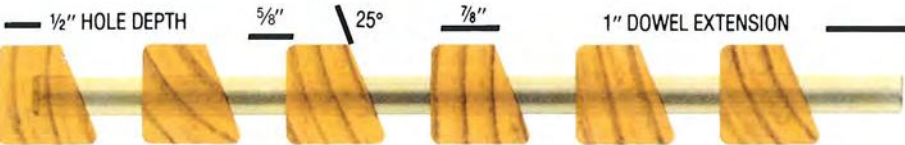

1 3/8" FRAMING THICKNESS

848L

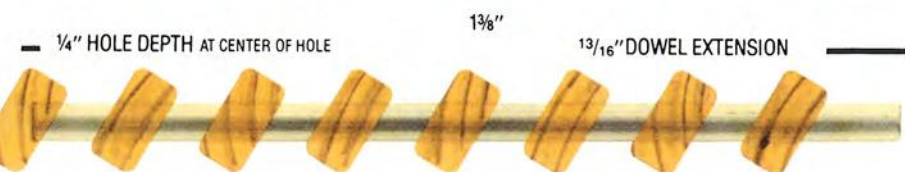

1 1/2" FRAMING THICKNESS

948L



1 1/2" FRAMING THICKNESS

12 INCH MODULE

VENTWOOD® BENCH SYSTEM GENERAL CONSTRUCTION

All wood parts for our VENTWOOD Bench System are manufactured of "select clear" kiln dried lumber accurately machined to the required dimensions.

The wood dowels used in the manufacture of VENTWOOD are made from Alaska Cypress, one of the most durable woods, and highly resistant to decay. It also has an exceptionally low coefficient of expansion and contraction which means it is an extremely stable wood and ideal for wood parts which require a precise fit such as the dowels in VENTWOOD panels or for any other purpose where it is essential that the swelling, shrinking and checking of the wood be held to an absolute minimum.

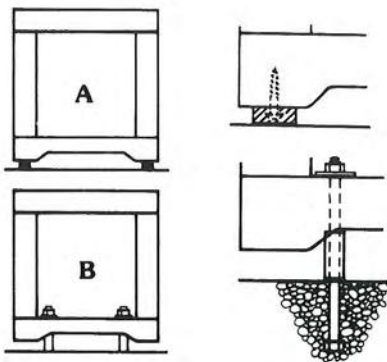
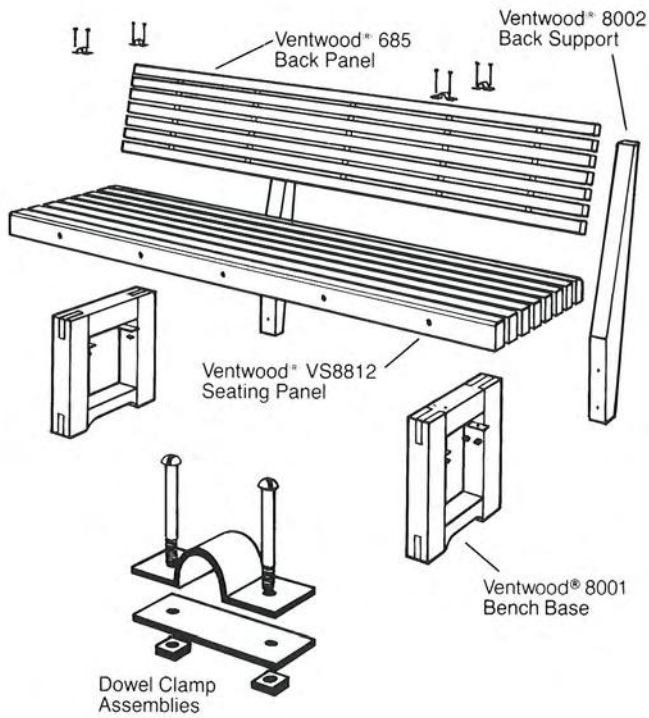

Bench Base feet can be protected from casual water by attaching rust proof pads to bottom of base. (See illustration A)

Permanent installations can be protected by slipping rust proof washers or sections of pipe or tubing over the bolts which firmly attach Bench Bases to concrete floor or pad. (See Illustration B)

EASED CORNERS, EXCEPT CORNERS ON PANEL FACE ARE ROUNDED

VS • 8812

VS • 10812

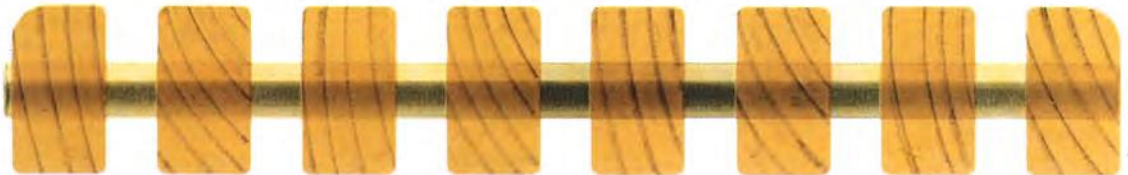

15 1/2" PANEL WIDTH

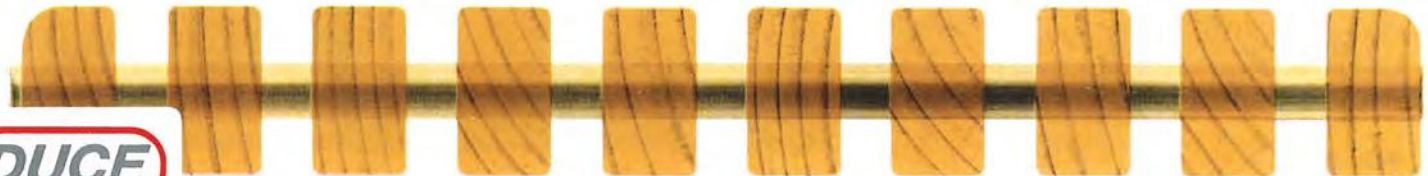

19 5/8" PANEL WIDTH



TIMBER WINDOWS & DOORS

BRISBANE IPSWICH
GOLD COAST CAIRNS
SUNSHINE COAST

Ph: (07) 3816 0244